

INDUSTRIAL PANEL COMPUTER IPC-500 SERIES

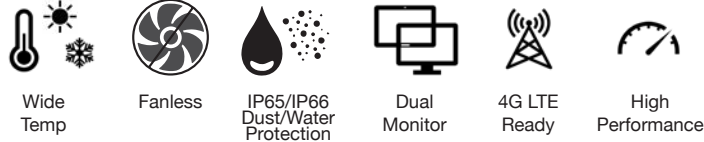

Fanless Touch Panel Computer with Configurable Intel® Kaby Lake™ i3/i5/i7 Core Processor, HDMI, DisplayPort, 2 GbE LAN, 6 USB, 3 COM, WiFi & 4G LTE Ready

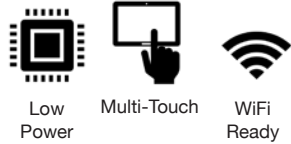

SYSTEM SPECIFICATIONS

Front Bezel	IP65/IP66, Aluminum enclosure
LCD Panel Sizes	15" / 15.6" / 17" / 19" / 21.5" / 23.8"
Brightness per panel	350 nits or 1600 nits / 400 nits / 350 nits or 800 nits / 350 nits or 1600 nits / 400nits / 400nits
Resolution per panel	1024 x 768 / 1920 x 1080 / 1280 x 1024 / 1280 x 1024 / 1920 x 1080 / 1920 x 1080
Touch Screen	Resistive or Projective Capacitive
Processor	Intel® i3-7100U 2.30GHz Intel® i5-7300U 2.60GHz Intel® i7-7600U 2.80GHz
Processor Generation	Kaby Lake™
Processor Cores	2
Memory	Up to 16GB DDR4 SO-DIMM
Storage	1 • mSATA up to 1TB
Chipset	SoC integrated
Graphics	Intel® HD Graphics 520
LAN Controller	Intel® I210-AT GbE LAN port Intel® I219LM GbE LAN port
System I/O	Front 2 • USB 2.0 ports 1 • Power Button 3 • RS232/422/485 ports 2 • WiFi RP-SMA connectors 2 • 4G SMA connectors Rear 4 • USB 3.0 ports 2 • Gb LAN Ports 1 • HDMI port 1 • DisplayPort 1 • Locking Power connector 2 • WiFi RP-SMA connectors 2 • 4G SMA connectors
BIOS	AMI UEFI
Watchdog Timer	256 levels, 1~255 sec.
Expansion Interface	1 • PCIe Mini Card (full height)
System Indicator	1 • blue LED for system power-on (shared) 1 • red LED for SSD active (shared)

MECHANICAL SPECIFICATIONS

Color	Silver-Blue
Construction	Aluminum extrusion and heavy gauge chassis
Dimensions (W x H x D)	
IPC-500S-150-	358.5mm x 281.5mm x 61.5mm (14.11" x 11.08" x 2.42")
IPC-500S-156-	387.4mm x 242.4mm x 56.5mm (15.25" x 9.54" x 2.22")
IPC-500S-170-	392.5mm x 325mm x 60.5mm (15.45" x 12.79" x 2.38")
IPC-500S-190-	439.5mm x 364.3mm x 60.5mm (17.30" x 14.34" x 2.38")
IPC-500S-215-	537.6mm x 329mm x 54.5mm (21.16" x 12.95" x 2.14")
IPC-500S-238-	596mm x 366mm x 80mm (23.46" x 14.40" x 3.24")
Mounting	VESA mount / Wall mount / Panel mount

FEATURES

- IP65/IP66 rated front bezel with resistive or PCAP touch screen
- LCD Panel Sizes: 15", 15.6", 17", 19", 21.5", 23.8"
- Configurable Intel® Kaby Lake™ i3/i5/i7 Core processor
- High performance 260-pin DDR4 2133 SO-DIMM, max. up to 16GB
- WiFi and 4G LTE Ready
- Highly reliable thermal transfer fanless technology
- 2 • RS232/422/485 and 6 • USB ports
- 256GB ~ 1TB mSATA supported
- 1 • Expandable PCI Express Mini Card slots
- Supports DisplayPort and HDMI dual display
- Wide range operating temperature supported



POWER SUPPLY

Power Input	12 ~ 24VDC with protection fuse
Power Adapter	110 ~ 240 AC to 12VDC out 60W

REGULATORY SPECIFICATIONS

Operating Temperature	-10°C ~ 60°C (14°F ~ 140°F)
EMI/EMC	CE standards applied (EN 55022 / EN 55024 / EN 55032 / EN 60950-1) FCC - Assembled using FCC certified components RoHS
Vibration	5~500Hz 1G PTP
Shock	operating: 30G (11ms), non-operating: 40G (11ms)

ORDERING INFORMATION

Base	IPC-500 Industrial Panel Computer, 15" 1024 x 768, XGA 350NIT LCD, Intel® Kaby Lake™ Processor, 4- USB 3.0 Ports, 2- USB 2.0 Ports, 1- Intel® I210-AT GbE LAN Port, 1- Intel® I219LM GbE LAN, 1- RS232 Ports, 1- RS232/422/485 Port. (Does not include AC Wall Adapter)
IPC-500_-150-	IPC-500 Industrial Panel Computer, 15.6" 1920 x 1080, FHD 400NIT LCD, Intel® Kaby Lake™ Processor, 4- USB 3.0 Ports, 2- USB 2.0 Ports, 1- Intel® I210-AT GbE LAN Port, 1- Intel® I219LM GbE LAN, 1- RS232 Ports, 1- RS232/422/485 Port. (Does not include AC Wall Adapter)
IPC-500_-156-	IPC-500 Industrial Panel Computer, 17" 1280 x 768, SXGA 350NIT LCD, Intel® Kaby Lake™ Processor, 4- USB 3.0 Ports, 2- USB 2.0 Ports, 1- Intel® I210-AT GbE LAN Port, 1- Intel® I219LM GbE LAN, 1- RS232 Ports, 1- RS232/422/485 Port. (Does not include AC Wall Adapter)
IPC-500_-170-	IPC-500 Industrial Panel Computer, 19" 1280 x 1024, SXGA 350NIT LCD, Intel® Kaby Lake™ Processor, 4- USB 3.0 Ports, 2- USB 2.0 Ports, 1- Intel® I210-AT GbE LAN Port, 1- Intel® I219LM GbE LAN, 1- RS232 Ports, 1- RS232/422/485 Port. (Does not include AC Wall Adapter)
IPC-500_-190-	IPC-500 Industrial Panel Computer, 21.5" 1920 x 1080, FHD 400NIT LCD, Intel® Kaby Lake™ Processor, 4- USB 3.0 Ports, 2- USB 2.0 Ports, 1- Intel® I210-AT GbE LAN Port, 1- Intel® I219LM GbE LAN, 1- RS232 Ports, 1- RS232/422/485 Port. (Does not include AC Wall Adapter)
IPC-500_-215-	IPC-500 Industrial Panel Computer, 23.8" 1920 x 1080, FHD 400NIT LCD, Intel® Kaby Lake™ Processor, 4- USB 3.0 Ports, 2- USB 2.0 Ports, 1- Intel® I210-AT GbE LAN Port, 1- Intel® I219LM GbE LAN, 1- RS232 Ports, 1- RS232/422/485 Port. (Does not include AC Wall Adapter)

INDUSTRIAL PANEL COMPUTER IPC-500 SERIES



CONFIGURABLE & ACCESSORIES

Power Connector	Locking Circular Barrel Power Connector, 3-Pin Terminal Block Connector with Mate
High Bright LCD	15" - 1600 nits / 17" - 800 nits / 19" - 1600 nits
Touch Screen	Projective Capacitive or Resistive
RS232/RS485 Ports	2 - RS232/485 Ports on Front Panel
mSATA SSD	256GB, 512GB, 1TB
Additional Dual Ethernet	Dual Ethernet Ports (Total of 4) 2 • Front Panel - 2 • Rear Panel
DDR3L SO-DIMM	4GB or 8GB
WiFi module	Intel® 8265 802.11ac/a/b/g/n Wi-Fi / Bluetooth M.2 Module
4G LTE module	Sierra Wireless LTE - Verizon® or AT&T® 4G M.2 Module

CONFIGURABLE & ACCESSORIES

VESA mount kit	VESA2-KIT
Wall mount bracket	6680440721
Panel mount kit	9601340301
AC wall adapter	3771030341
Operating System	Windows® 10 IoT Enterprise 2016 LTSC Value (i3/i5), Windows® 10 IoT Enterprise 2019 LTSC Value (i3/i5), Windows® 10 Professional 64bit, Ubuntu® Desktop 16.04 LTS 64bit

WARRANTY

Standard Warranty	2 Year Warranty
Extended Warranty	TotalCare Protection 3 or 5 Year Extended
Expected Life Cycle	7 Years

DIMENSIONS

IPC-500_-150

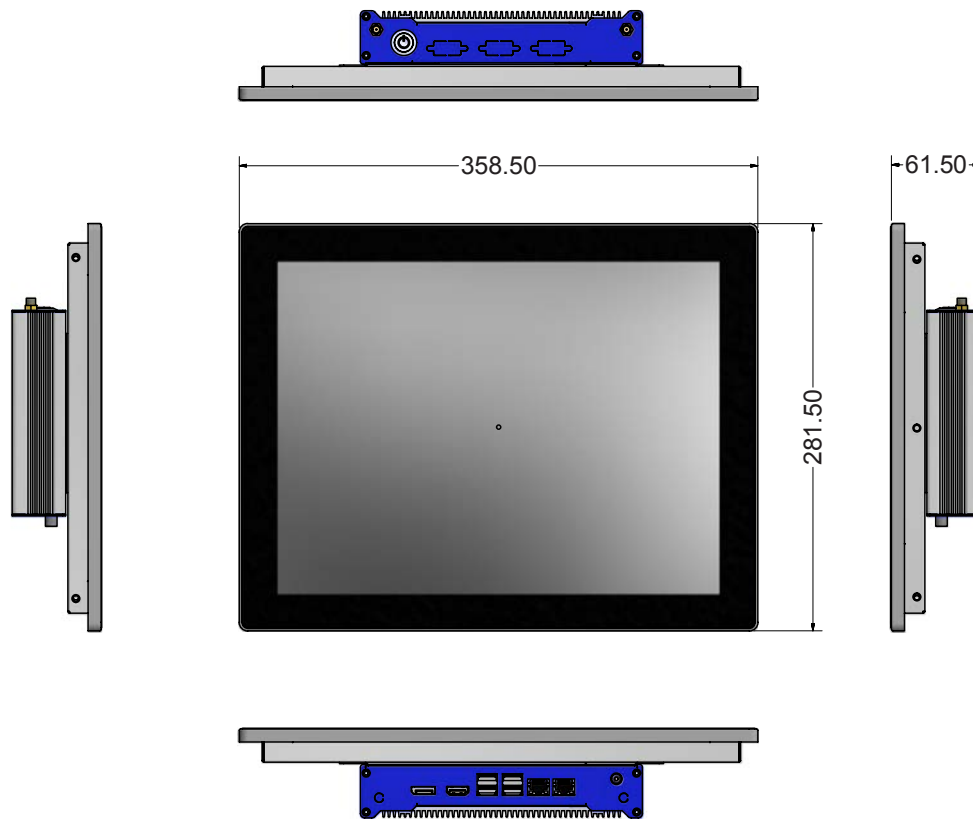

Measurements shown in mm. All dimensions are ± 0.5mm

DIMENSIONS

IPC-500_-156

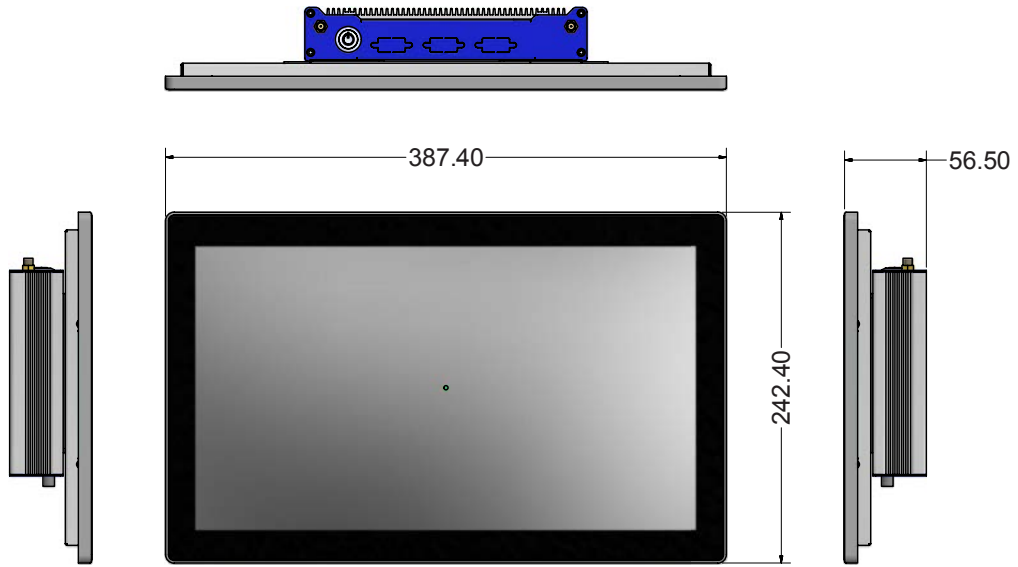

IPC-500_-170

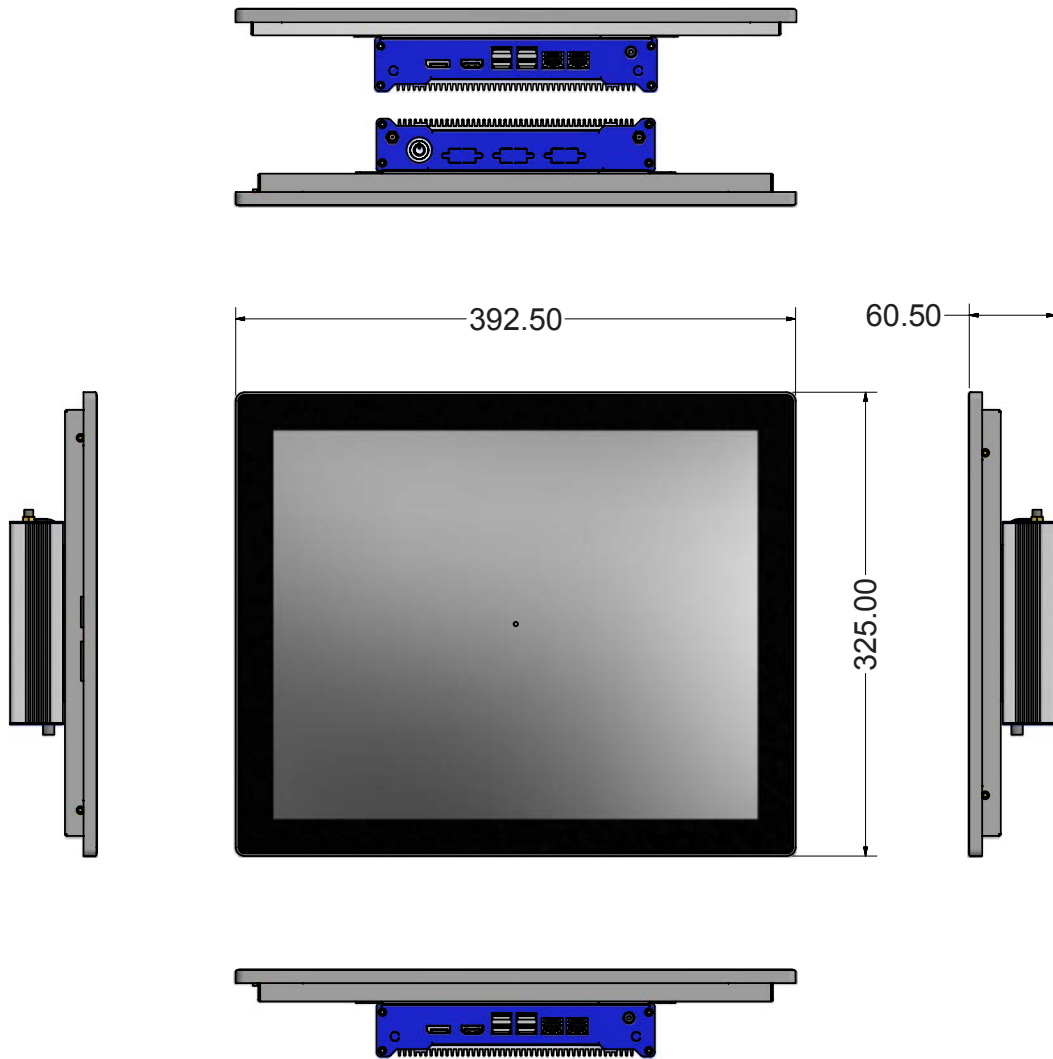

Measurements shown in mm. All dimensions are ± 0.5 mm

DIMENSIONS

IPC-500_-190

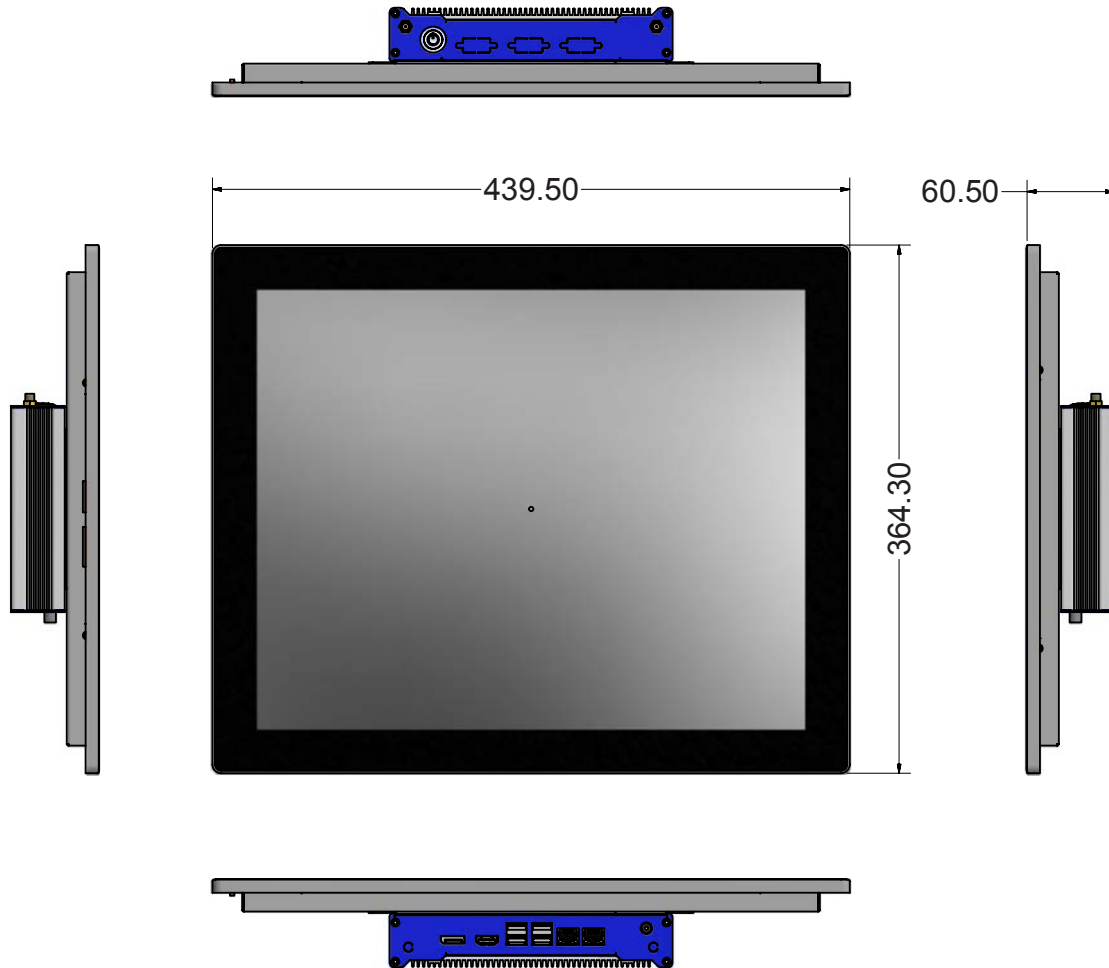

Measurements shown in mm. All dimensions are ± 0.5 mm

INDUSTRIAL PANEL COMPUTER IPC-500 SERIES



DIMENSIONS

IPC-500_-215

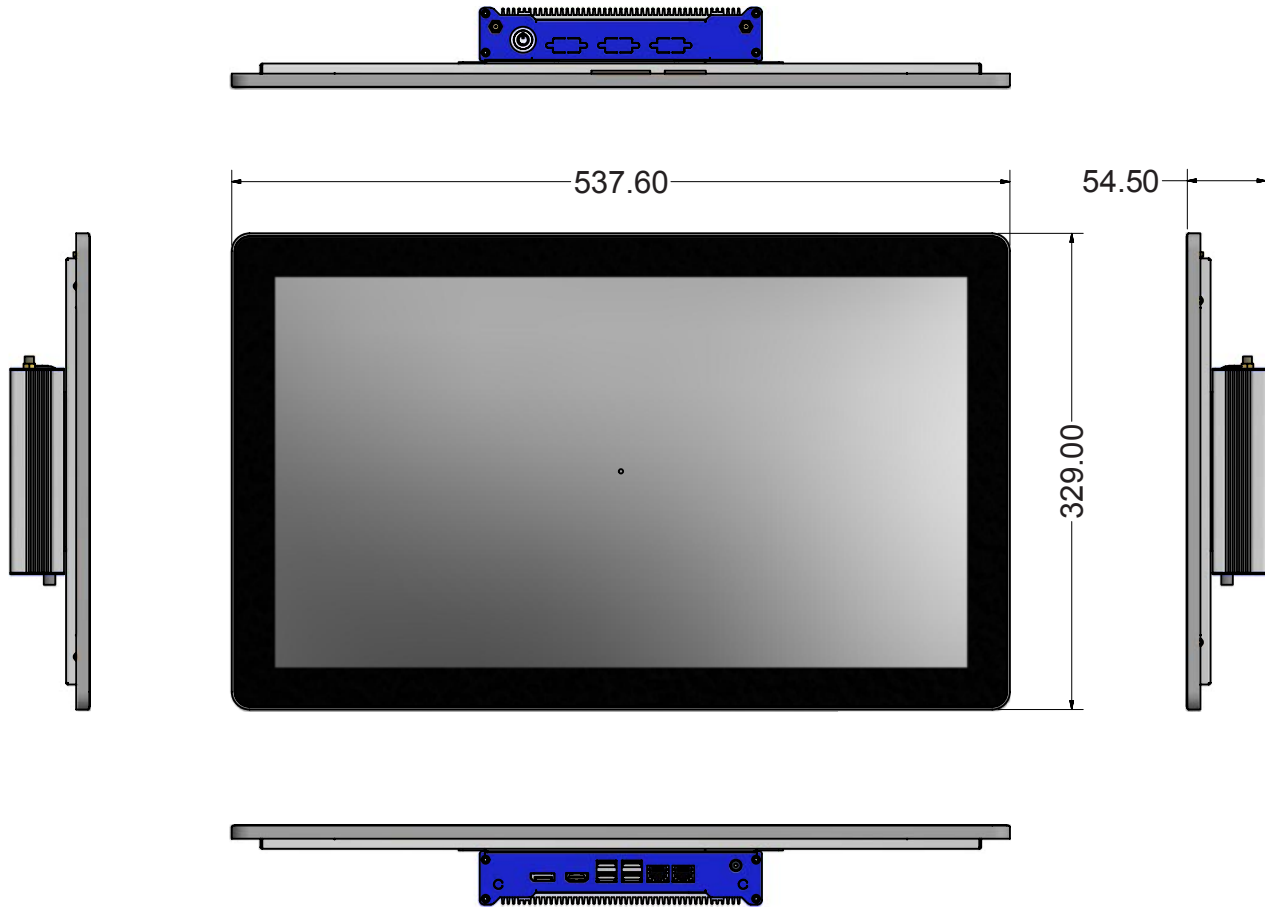

Measurements shown in mm. All dimensions are ± 0.5 mm

INDUSTRIAL PANEL COMPUTER IPC-500 SERIES



DIMENSIONS

IPC-500_-238

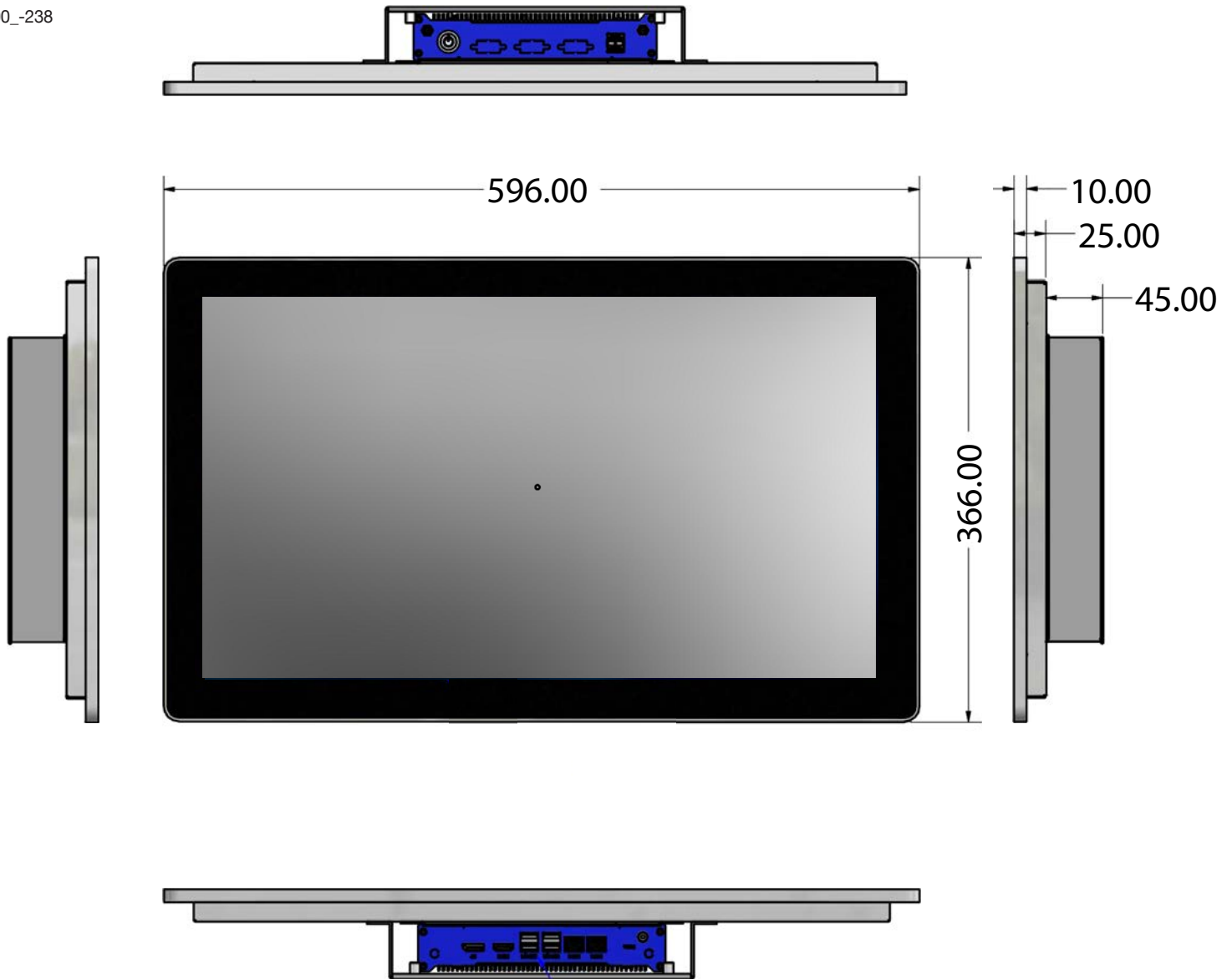

Measurements shown in mm. All dimensions are $\pm 0.5\text{mm}$